

REVISIONS				
P.	LTM	DESCRIPTION	DATE	OWN APVD
	A8	REVISED PER ECO-15-003872	25MAR2015	DD DS

- 1 ACCEPTS #3 SELF TAPPING THREAD FORMING SCREWS OR METRIC EQUIVALENT. DRIVE TO 0.6-0.8 N-m.
- 2 DATE CODE TO BE BRANDED IN THIS LOCATION PER TE SPEC 102-60. USE 5 DIGIT CODE: FIRST 2 DIGITS = YEAR, SECOND 2 DIGITS = WEEK, LAST DIGIT = DAY.
- 3 MATERIALS: HEADER HOUSING - GLASS FILLED PBT
PINS - TIN OR GOLD PLATED BRASS
GASKET - SILICONE
- 4 HOUSING COLORS ARE MECHANICALLY KEYED TO MATE ONLY WITH IDENTICALLY COLORED PLUG ASSEMBLIES.
- 5. HEADER MATES TO PLUG ASSEMBLY 776273 WHICH USES REELED TERMINAL 770520 OR LOOSE PIECE TERMINAL 770854

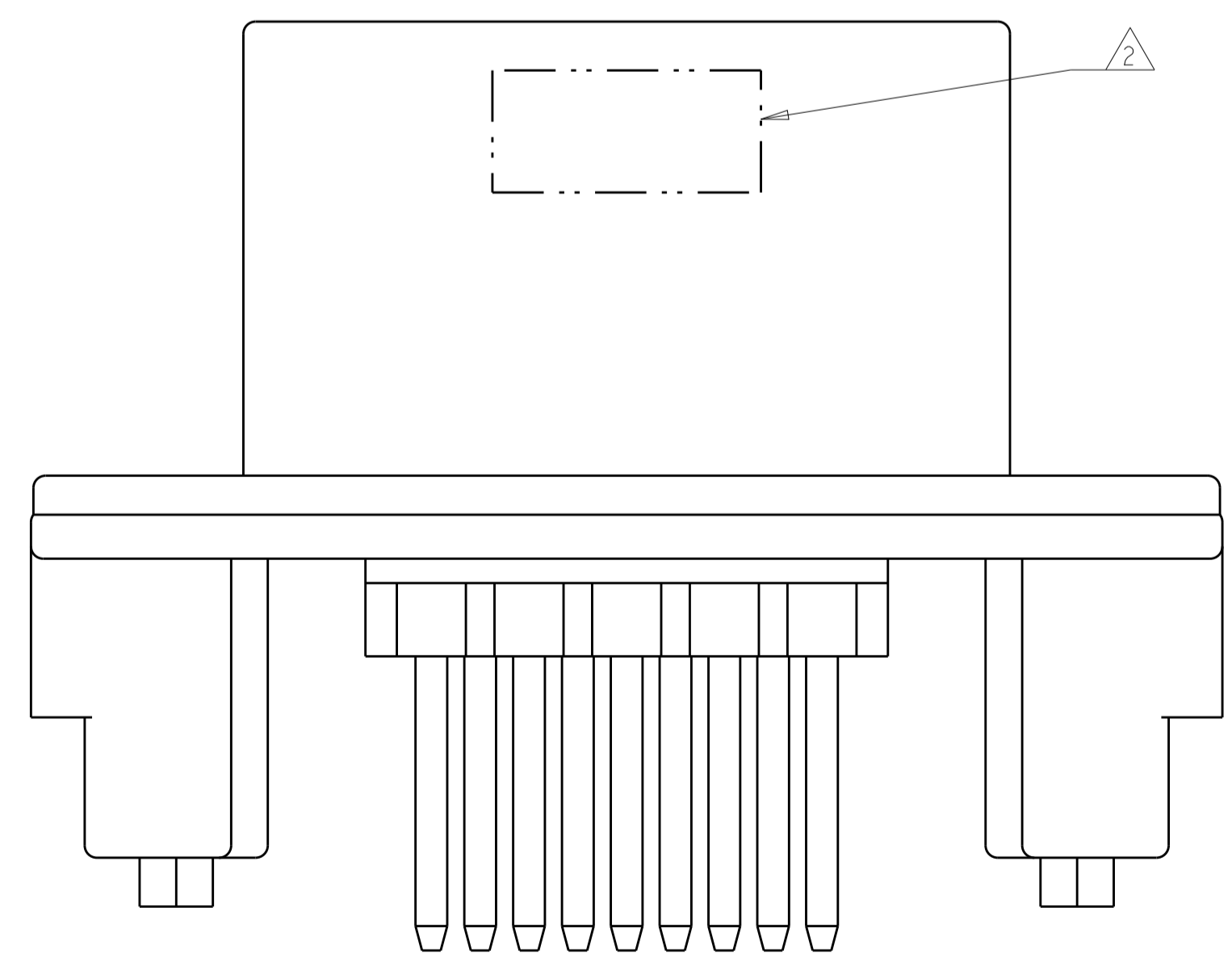
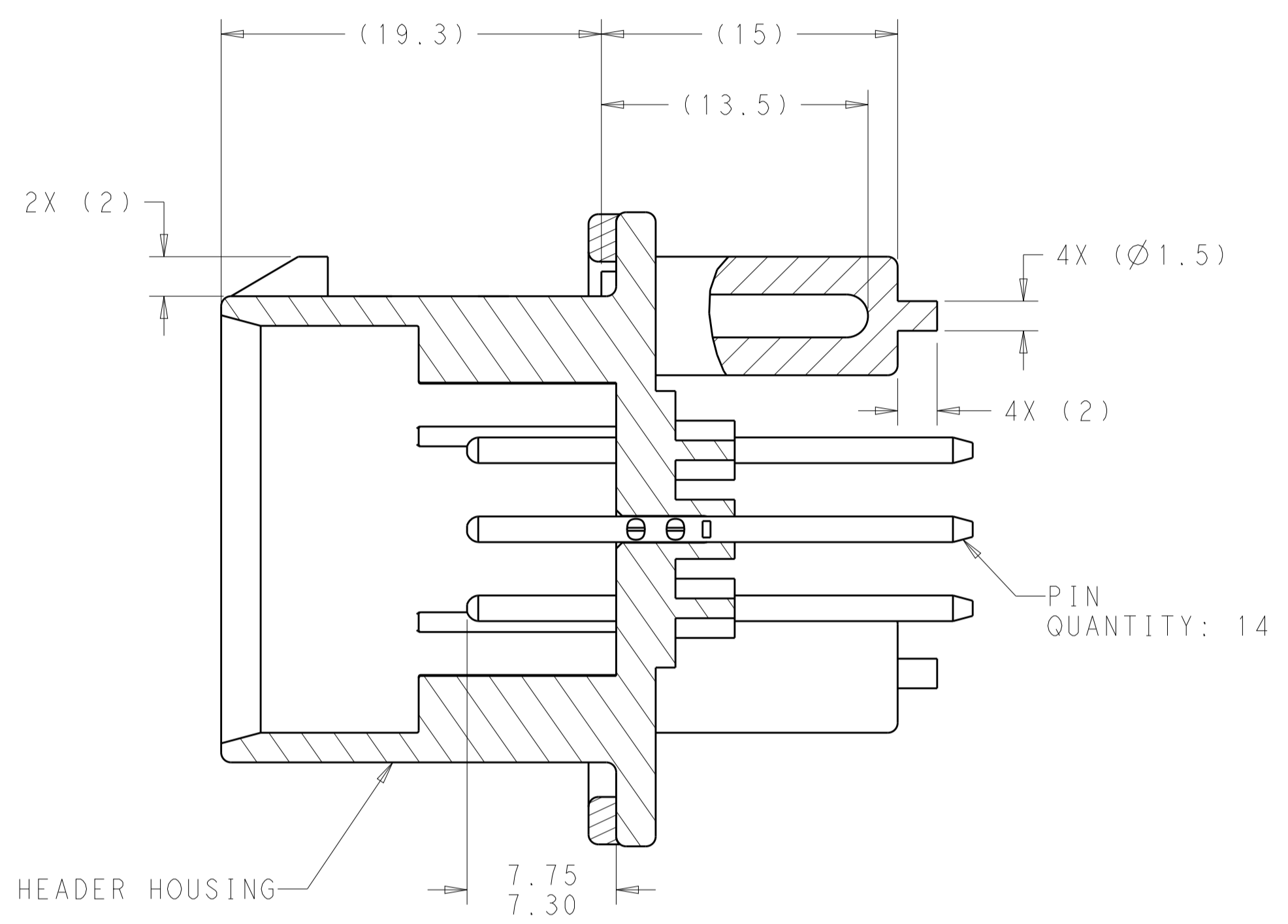
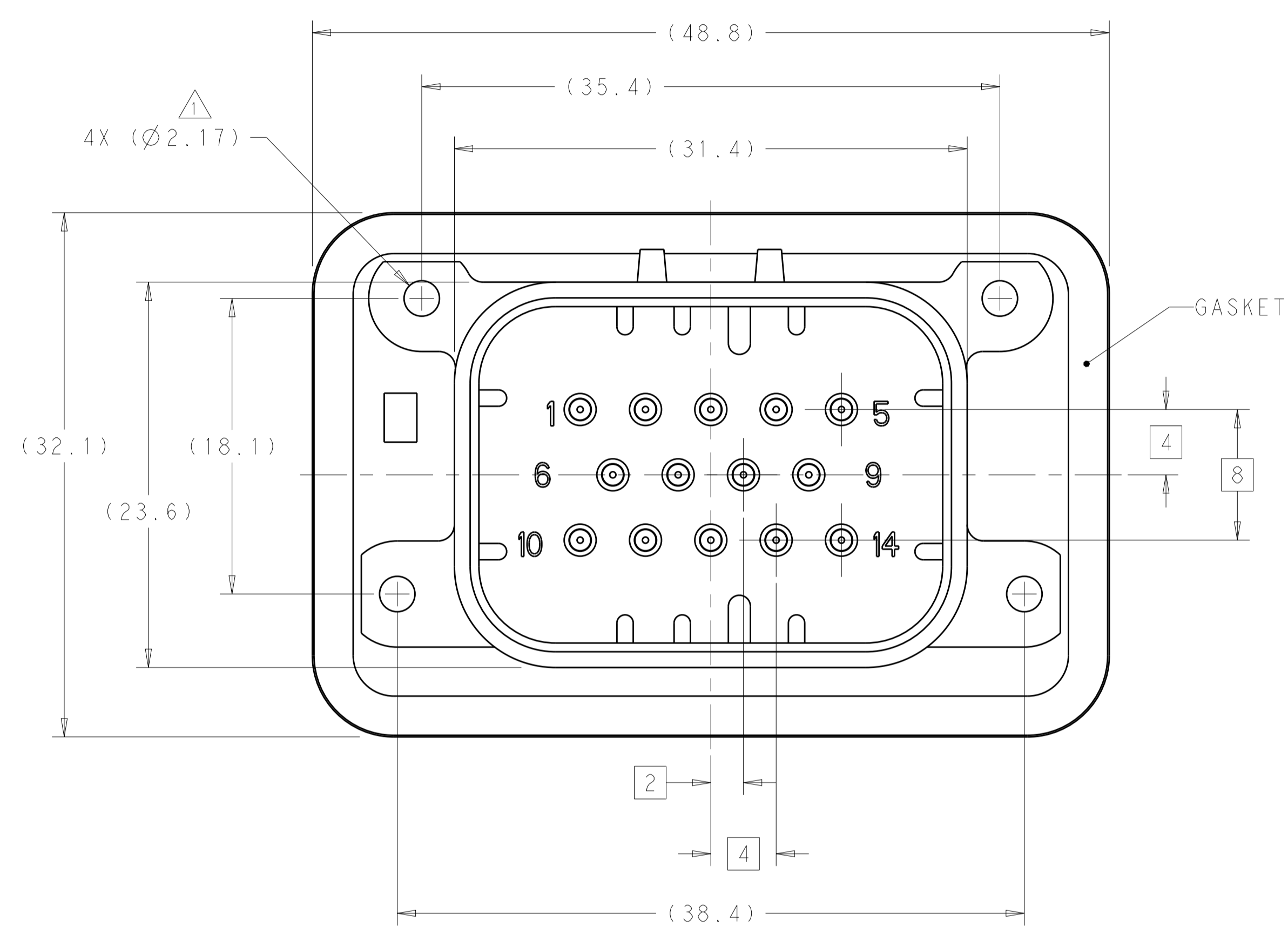

776262-1 & 1-776262-1 SHOWN

HEADER COLOR	PLATING	PART NUMBER
BLUE	DURAGOLD	1-776262-5
GRAY	DURAGOLD	1-776262-4
NATURAL	DURAGOLD	1-776262-2
BLACK	DURAGOLD	1-776262-1
BLUE	TIN	776262-5
GRAY	TIN	776262-4
NATURAL	TIN	776262-2
BLACK	TIN	776262-1

THIS DRAWING IS A CONTROLLED DOCUMENT.		OWN: D. STRAUSSER 03MAR2010	TE Connectivity	
DIMENSIONS: mm		CHK: D. STRAUSSER 25MAR2010		
TOLERANCES UNLESS OTHERWISE SPECIFIED:		APVD: D. STRAUSSER 27APR2010	NAME: ASSEMBLY, HEADER, 14 POSITION, VERTICAL, AMPSEAL WITH FLANGE SEAL	
0 PLC ±0.2		PRODUCT SPEC: 108-1329	SIZE: A100779C=776262	
1 PLC ±0.13		APPLICATION SPEC: 114-16016	RESTRICTED TO: -	
2 PLC ±0.1		WEIGHT: -	SCALE: 4:1 SHEET 1 OF 2 REV: A8	
3 PLC ±0.075		CUSTOMER DRAWING		
ANGLES ±0.5°				
FINISH: 3				

REVISIONS				
P.	LTN.	DESCRIPTION	DATE	APVD.
-	-	SEE SHEET 1	-	-

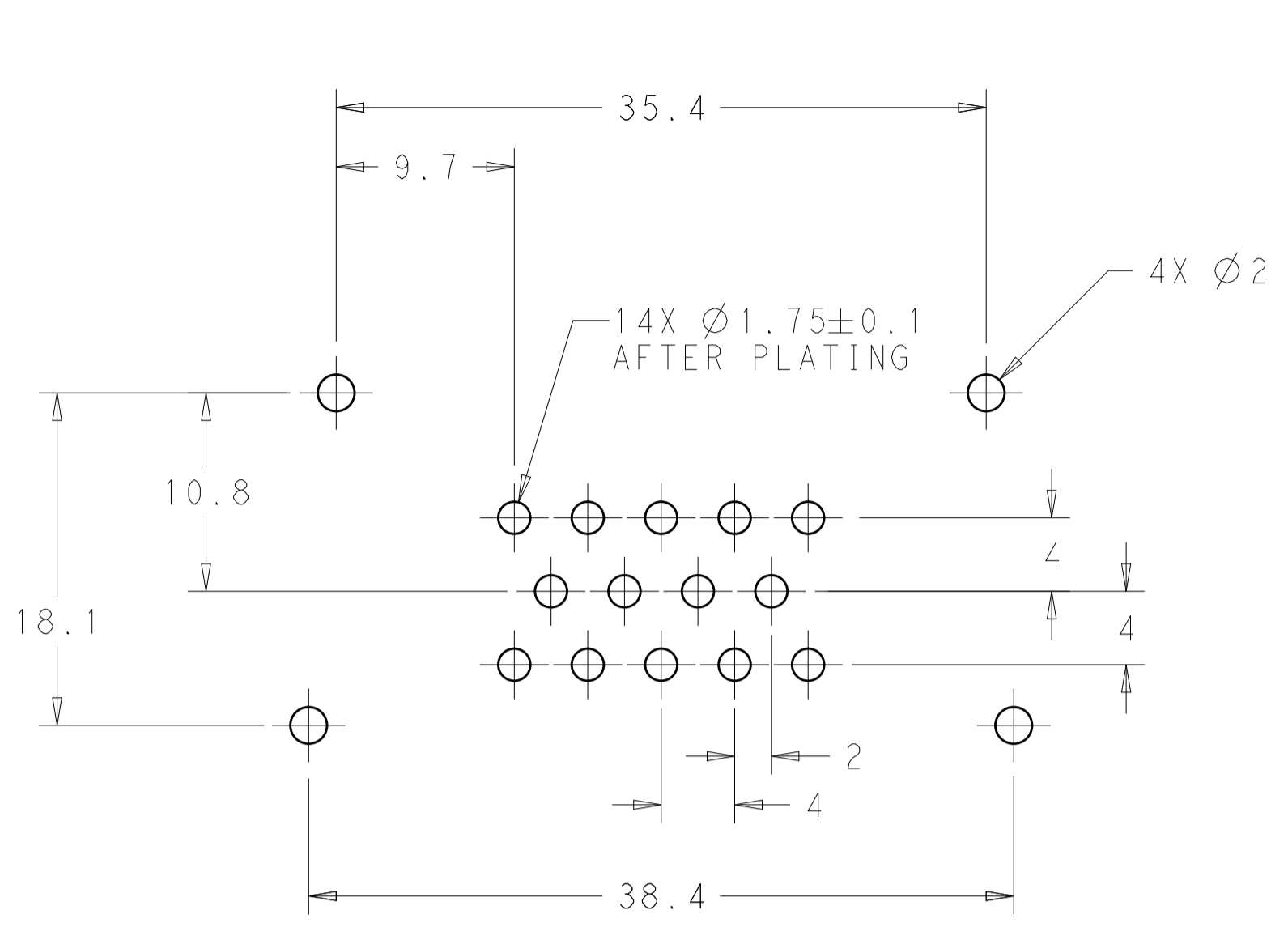

RECOMMENDED P.C. BOARD LAYOUT FOR 1.57 THICK P.C. BOARD

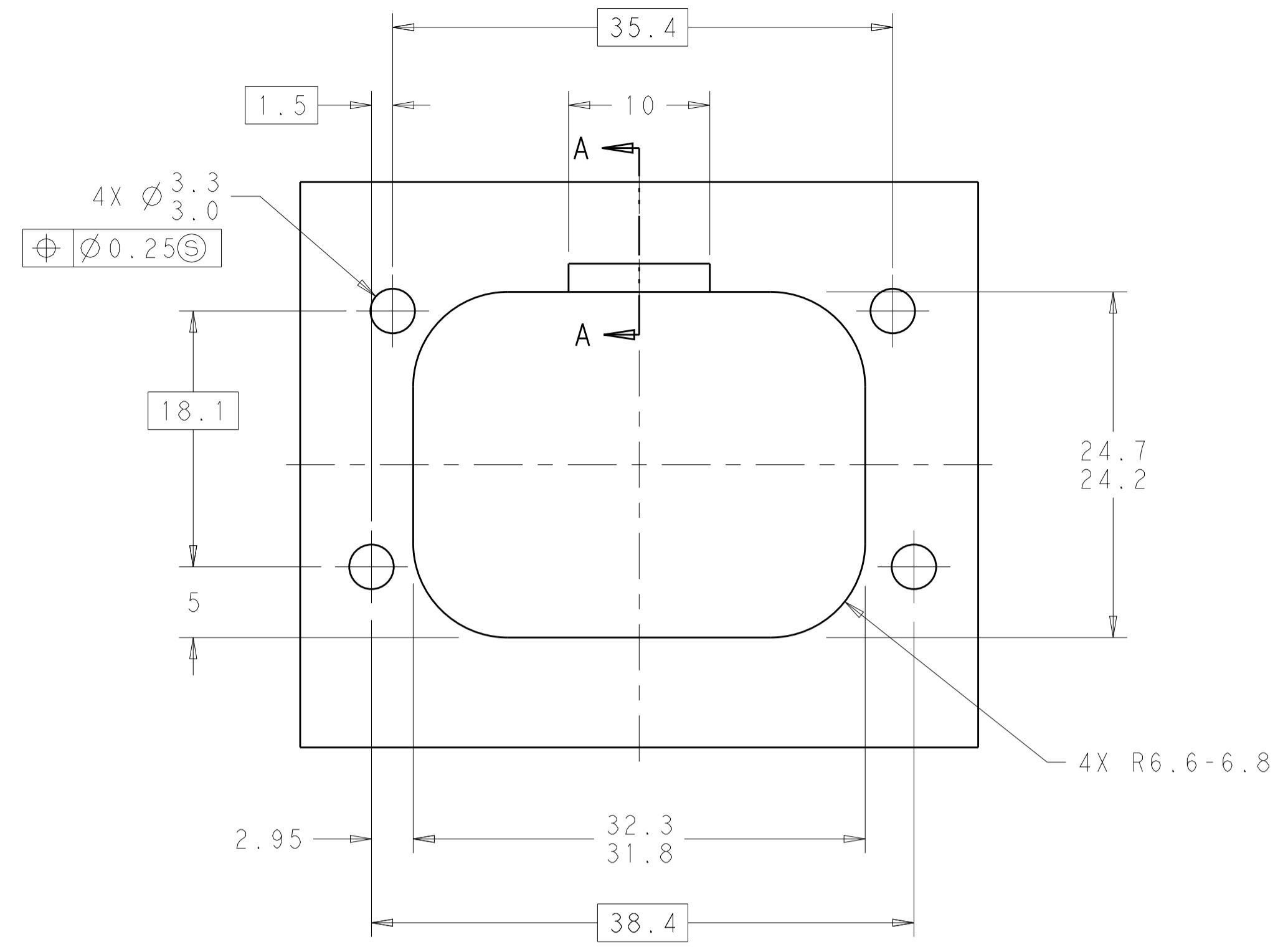

RECOMMENDED MOUNTING HOLE LAYOUT FOR 5.0 MAX THICK PANEL

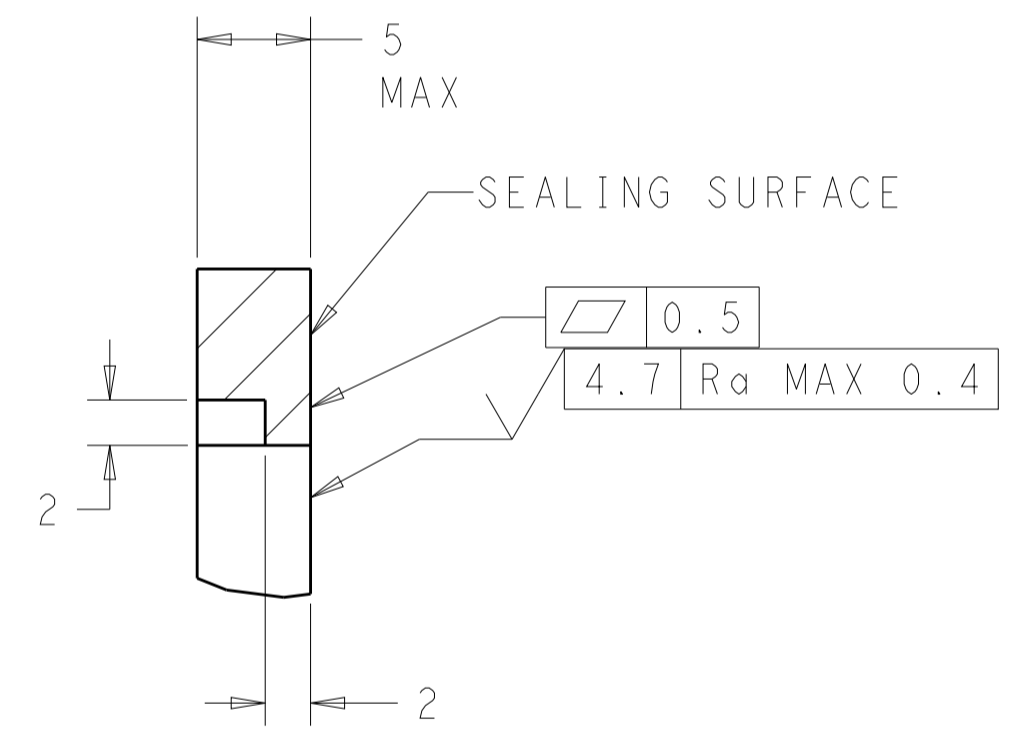
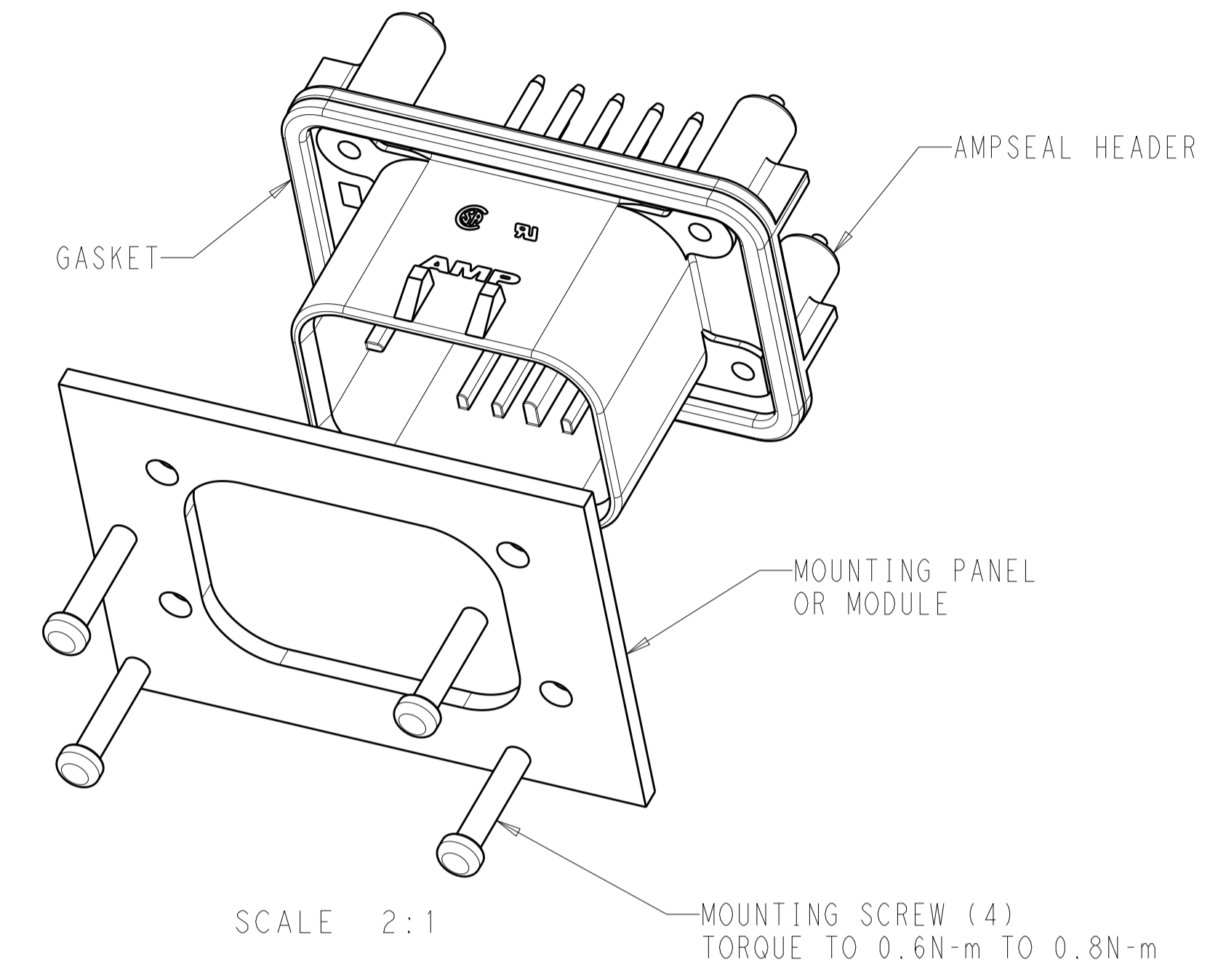

SECTION A-A
OPTIONAL CONSTRUCTION IF PANEL THICKNESS IS GREATER THAN 2.0

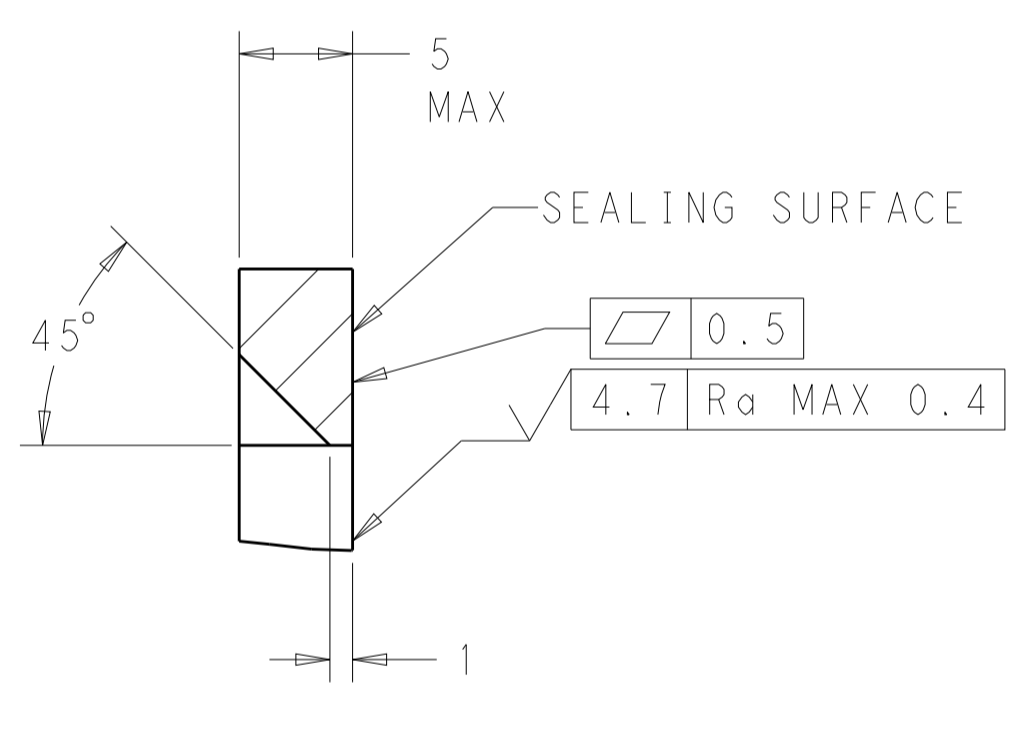

SECTION A-A
OPTIONAL CONSTRUCTION IF PANEL THICKNESS IS GREATER THAN 2.0

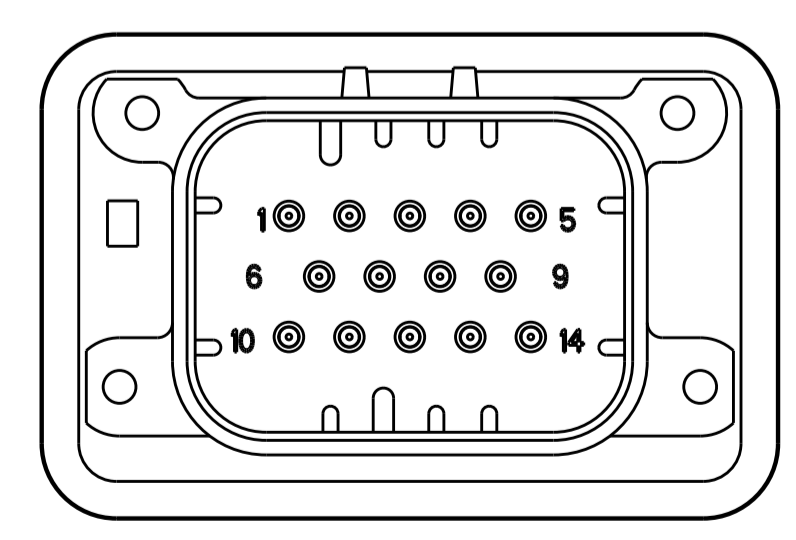
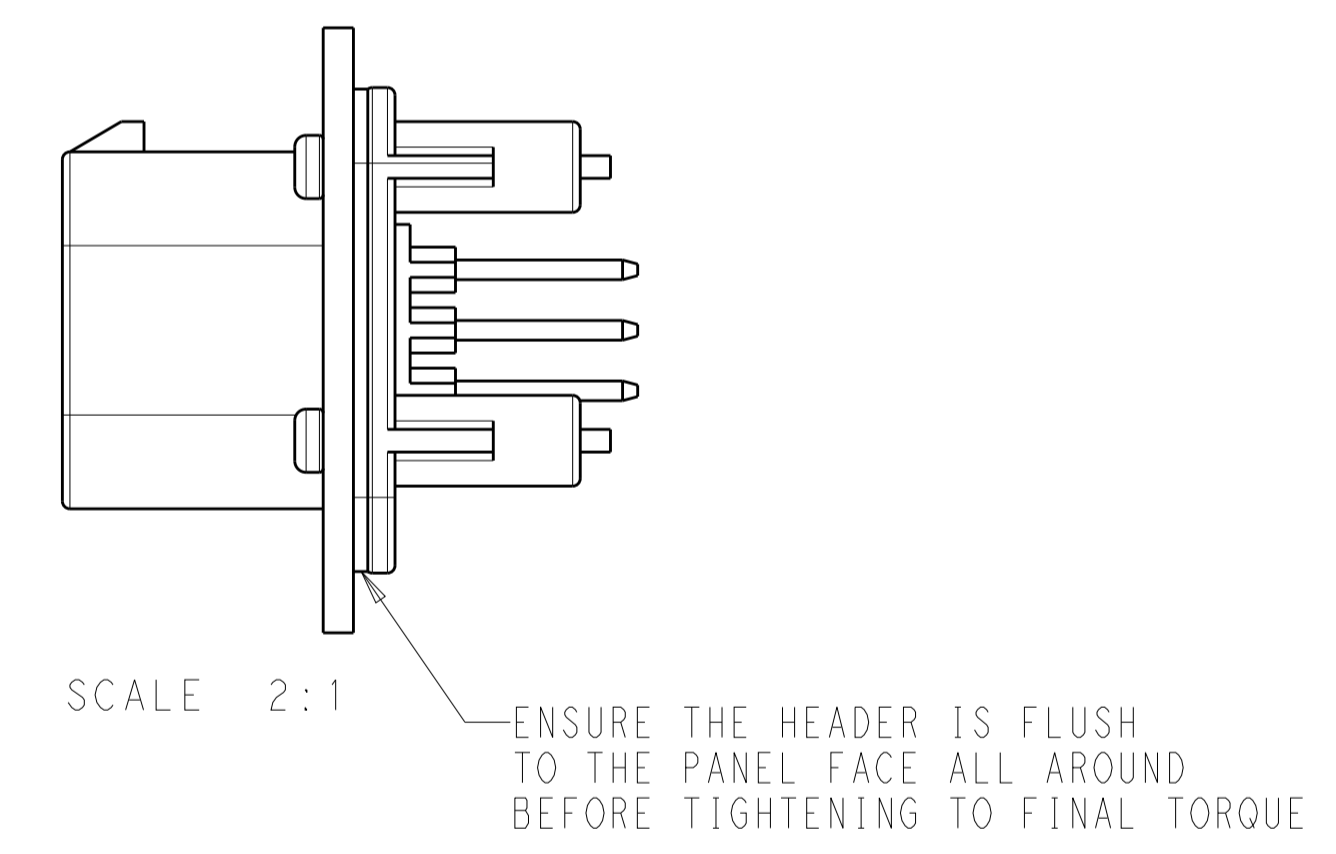

776262-2 & 1-776262-2
KEY LOCATION
SCALE 2:1

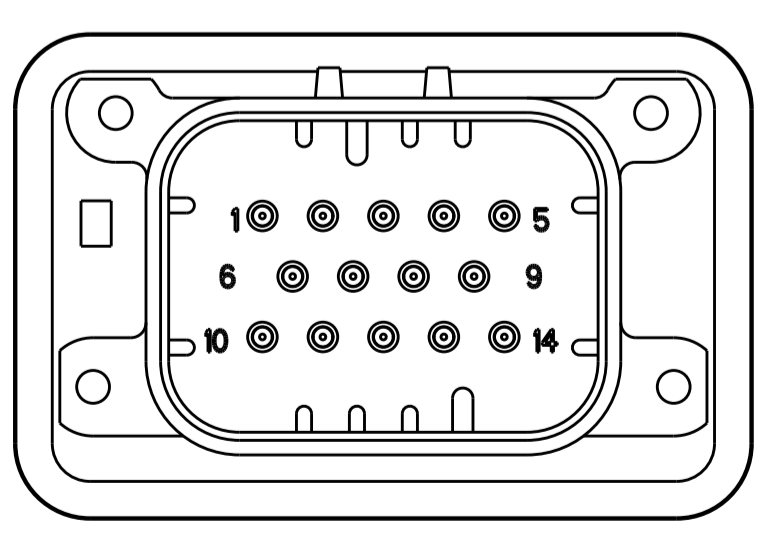

776262-4 & 1-776262-4
KEY LOCATION
SCALE 2:1

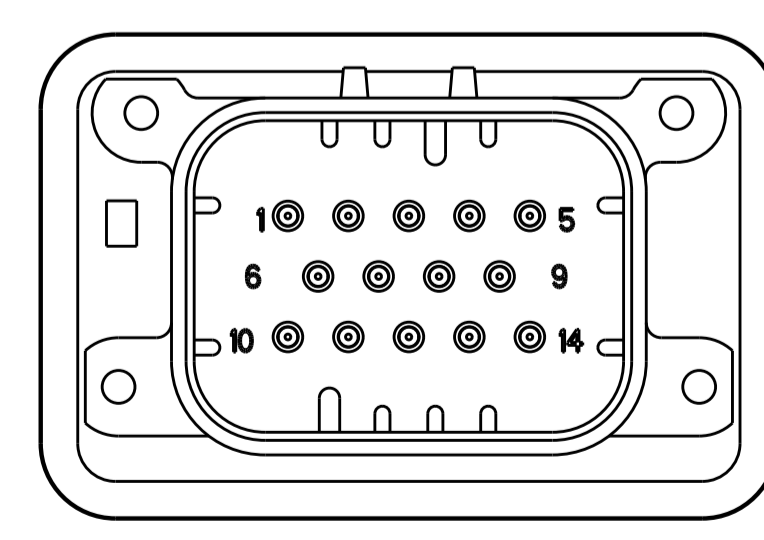

776262-5 & 1-776262-5
KEY LOCATION
SCALE 2:1

THIS DRAWING IS A CONTROLLED DOCUMENT.		DWN: D. STRAUSSER 03MAR2010 CHK: D. STRAUSSER 22MAR2010 APVD: D. STRAUSSER 27APR2010	TE Connectivity	
DIMENSIONS: mm 		TOLERANCES UNLESS OTHERWISE SPECIFIED: 0 PLC ±0.2 1 PLC ±0.13 2 PLC ±0.13 3 PLC ±0.13 4 PLC ±0.13 ANGLES ±1°	NAME: ASSEMBLY, HEADER, 14 POSITION, VERTICAL, AMPSEAL WITH FLANGE SEAL PRODUCT SPEC: 108-1329 APPLICATION SPEC: 114-16016	RESTRICTED TO:
MATERIAL: -		FINISH: -	WEIGHT: - CUSTOMER DRAWING	SIZE: A100779 CAGE CODE: 776262 SCALE: 2:1 SHEET 2 OF 2 REV: A8